

# **KENT-MOORE**

## **PT 2075 PORTA-MATIC**

# **I N S T R U C T I O N S**

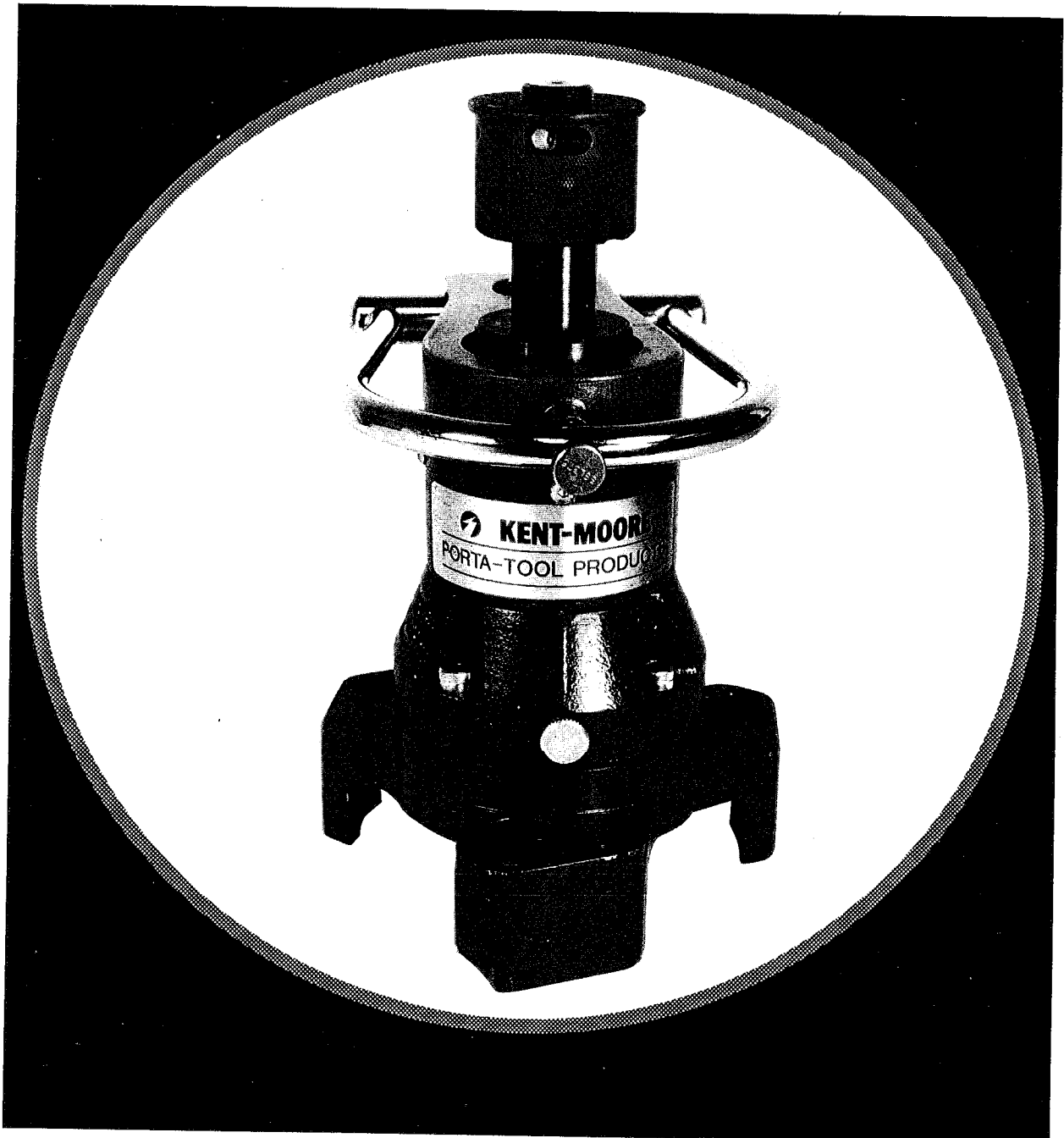

# KENT-MOORE

## PT-2075 PORTA-MATIC

### TOOL FUNCTION:

PT 2075 Porta-Matic is used to salvage engine block counter bores which are cracked, damaged or have been counter bored to their maximum depth. The original counterbore ledge is machined out using the Porta-Matic and a Kent-Moore repair bushing/insert is installed. When installed, the repair bushing/insert creates a new counterbore which must be finished-cut using PT 2475 Counterbore Cutter to bring it back to original manufacturer's specifications.

Additional kits and accessories are available for use with PT 2075. See below for details and engine description.

### PT 2075 Consists of:

No.	Part No.	Description	Amount
1	PT 2075-413	Basic Machine	1
2	PT 1000-20A	Universal Drive	1
*3	PT 2000-19	Driver Handle (not included)	1
4	PT 2000-138	Depth Set Collar	1
5	PT 2000-178	Micrometer Block	1
6	PT 2000-29	Micrometer Setting Standard	1
7	PT 2000-28	Cutter Removal Key	1
8	PT 2100-42	Steel Box (Not Shown)	1
9	PT 2000-212	Micrometer Storage Box (Not Shown)	1
10	RS 9107-275	.625 11x3.75 Head Bolt 3300 Series	3
11	RS 9107-685	.750 16x4.00 Head Bolt 3400 Series	3
12	PT 2000-62	7/8" Off-Set Washer	3
13	RS 13300-250	.625 SAE Washer 3300 Series	3
14	RS 13300-275	.750 SAE Washer 3400 Series	3
15	RS 15100-225	5/32" Short Arm Hex Key (not shown)	1
16	RS 15100-175	1/8" Short Arm Hex Key (not shown)	1
17	RS 15100-100	3/16" Short Arm Hex Key (not shown)	1

### CONVERSION KIT

A typical conversion kit for PT 2075 consists of: cutter, cutter plate, guide plate, driver plate, driver shaft, washer and jam nut

- PT 2000-78 Caterpillar Conversion Kit 4.75, 3306
- PT 2000-81A Caterpillar Conversion Kit 5.4, 3406  
(For Cat 5.4-3406 also order Pt 2100-45 Driver Shaft and PT 2100-46 Guide Plate).

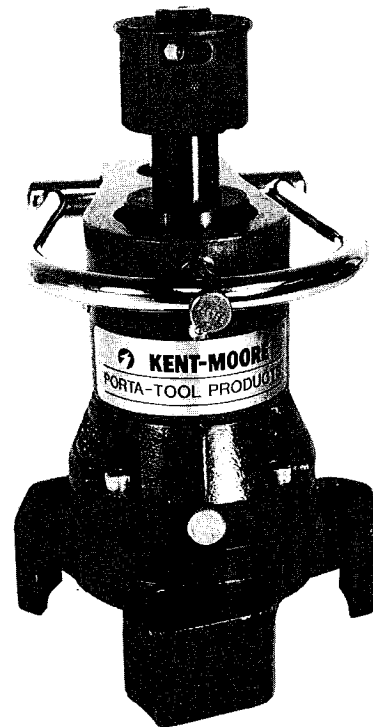

\* PT 2000-19 Driver Handle is needed to install bushings when using conversion kits PT 2000-78 and PT 2000-81A.

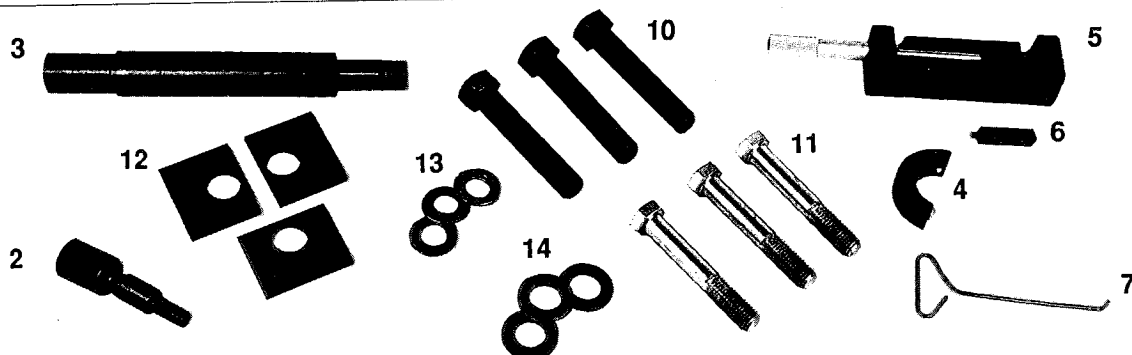

**Y**our Porta-Matic has been manufactured to very precise specifications. A great deal of care and craftsmanship went into the manufacturing of this tool so that you may enjoy years of trouble-free service. Each and every Porta-Matic is tried and tested before it leaves our factory. Your Porta-Matic is a precision piece of machinery which requires all the care you would provide for any type of precision equipment. Care and maintenance is simple and need only be done periodically to insure complete satisfaction from this tool.

Please adhere to the following guidelines for years and years of trouble-free machining:

## PREPARATION FOR MACHINING

### A. CARE AND MAINTENANCE OF THE HYDRAULIC-FEED HOUSING

Although your Porta-Matic was inspected and tested before leaving our factory, the oil level should always be checked prior to initial use. If a low oil condition exists, tool chatter will occur. Your oil level should also be checked periodically to prevent chatter (once a month is sufficient).

#### TO CHECK OIL LEVEL:

(Add only 30 weight non-detergent motor oil.)

Lay the feed unit on its side with the oil port in the highest position (see page 10). Support the feed unit so that it lays in the horizontal position. Remove the oil port plug. The feed unit is full when the oil is filled up into the threads. If the oil level is below the threads then top off using only 30 weight non-detergent motor oil. Open feed valve and slowly rotate and push the mainshaft in and out. Top off oil level any time the oil level drops below threads, continue this procedure until no more bubbles appear and oil level is maintained into the threaded area. Replace oil port plug.

#### NOTE:

The hydraulic feed may slowly settle down into a rest position when left in up position. This is normal and does not indicate a problem with the Porta-Matic. If this happens, it will be necessary to unlock the feed to return the unit to its full up position.

### B. CUTTER PLATE INSPECTION

Always inspect your cutter plate before proceeding. Make sure you have the correct plate for your application. Inspect it for burrs or sharp edges (it should be smooth). Inspect and adjust the ball spring plunger screw (brass colored) which provides tension to the cutter bit. To adjust this screw to the proper tension, you must first install a cutter bit into the cutter slot. Tighten down the tension screw completely. Then back the screw 1/4 of a turn. Cutter tension is now properly adjusted.

### C. VERIFYING THE MICROMETER BLOCK

The micrometer is pre-set at the factory. However, due to handling during shipping, it may be out of specification. It is recommended that the Micrometer Block be checked prior to setting the cutter. Always clean all measuring surfaces before using micrometer, setting standard or cutter. Inspect cutter stop (B) and cutter tip for nicks, if damaged, replace.

1. Use PT 2000-29 Setting Standard (A) to verify the Micrometer reading. Place setting standard with side stamped "UP" between cutter stop "B" and the micrometer spindle (E). Hold setting standard firmly against cutter stop (B) and surface (F) when checking setting standard or setting cutter. Turn Micrometer Thimble until spindle (E) fits snugly against the setting standard. The Micrometer should read 5.000".
2. When Micrometer adjustment is required, loosen socket head set screw (C) and move Micrometer slightly away from cutter stop (B). Set Micrometer to read 5.000".
3. Slide Micrometer to fit snugly against setting standard (A) and securely tighten socket head cap screw (C).
4. Back off Micrometer (D) and re-tighten to fit snugly against setting standard (A). Recheck the Micrometer which should read 5.000".

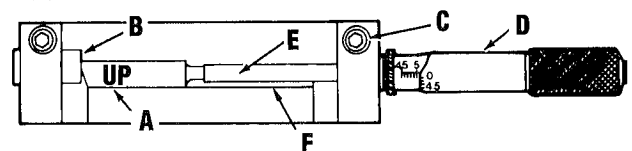

### D. VERIFYING THE SETTING STANDARD

If you suspect your setting standard to be damaged or inaccurate, use the following procedure:

1. Always check Micrometer Block first. See "Verifying the Micrometer Block" instructions.
2. Use scrap engine block to perform this check.
3. Measure bore in block, add  $+.040$ " to measured bore. This will be your test bore dimension.

#### Example:

Bore measured	6.295"
Add	<u><math>+.040</math>"</u>
Test bore size	6.335"

4. Set cutter to 6.335" dimension.
5. Bore hole and measure.
6. Compare against set cutter dimension.

# KENT-MOORE

## PT-2075 PORTA-MATIC

### Example:

If measured bore is 6.336" it is oversize by .001". Setting standard would require .0005" material removal, lap to size by removing material from stem side of setting master.

If bore measures undersize, example 6.334", then setting standard (PT 2000-29) should be replaced. Order setting standard oversize (PT 2000-29) and follow instructions "Machining Setting Standard to Size."

### NOTE:

Undersize bore cuts can be caused by damaged setting standard or worn bushings in machine.

## E. MACHINING SETTING STANDARD TO SIZE

### NOTE:

Use Scrap Engine Block to perform this test.

1. Measure bore in block, add +.040" to measured bore. This will be your test bore dimension.

### Example:

Bore measured	6.295"
Add	+.040"
Test bore size	6.335"

2. Set cutter, bore block and measure.
3. Verify cutter still measures original setting 6.335".
4. If size of newly cut bore is different than the 6.335" cutter setting then loosen micrometer holding screw and adjust micrometer to read actual bore size of newly cut hole.
5. Tighten micrometer holding screw at this measurement.
6. Place setting standard into micrometer and turn micrometer thimble down until spindle touches the setting standard.

### NOTE:

Setting Standard is .010" to .020" oversize.

7. Read your micrometer.
8. The difference between your micrometer reading and 5.000" is half the amount you will need to grind or lap the end of the setting standard (indicated by arrow) to read 5.000" on the micrometer.

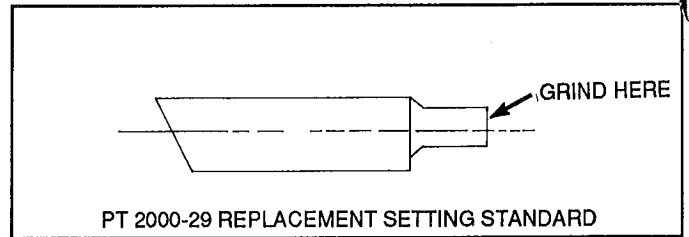

9. **CAREFULLY GRIND OR LAP SETTING STANDARD TO SIZE.** When you are finished, your micrometer should read 5.000". Your micrometer and setting standard are now set correctly!

## F. SETTING CUTTER FOR BORE DIAMETER

1. Loosen the set screw in back end of cutter. Push spring loaded adjusting pin into body of cutter all the way. Tighten set screw.
2. After verifying the Micrometer Block, set Micrometer for .040" less than the size bore your application calls for:

Example	Application	Bore to Dimension
1st Cut	Caterpillar 5.4 Bore	6.6250 Dia.
Final Cut	4.6 Cylinder	6.6650 Dia.

### NOTE:

It has been determined through testing, that when you take two cuts to machine for a bushing/insert, your bore will be much more accurate and have a higher quality surface finish.

Other engine applications and bore size information are detailed on Kent-Moore's bushing information sheet (Form PT 2000-169A). When machining for OEM stainless steel shims, refer to OEM specifications.

3. Place cutter in Micrometer Block and hold it firmly against the micrometer spindle - E and surface - F.
4. Loosen set screw - G on cutter and allow adjusting pin - H to push out against the Micrometer spindle. While holding cutter in place, slowly allow the cutter tip to come in contact with cutter stop - B. Tighten set screw.
5. Back off Micrometer thimble and recheck cutter setting. Back off Micrometer and remove cutter from Micrometer Block.

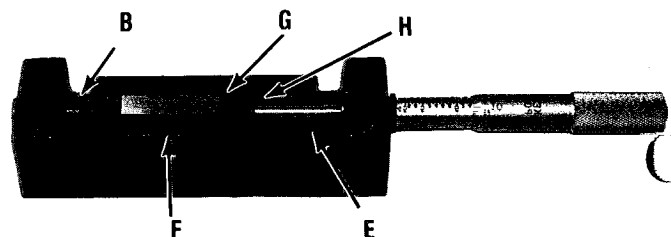

## G. PREPARING BLOCK FOR BORING

1. Steam clean block. Remove all top deck dowels and studs necessary using PT 6200 Stud-Out Tool or equivalent.
2. Remove all burrs and high spots from top deck with a large mill cut file (PT 2000-400 File).
3. Using Scotch Brite Pads PT 2901, remove all dents, dirt and burrs from the **INSIDE DIAMETERS OF THE COUNTERBORE**. This area is used by cutter plates to center the Porta-Matic over the bore.

## MACHINING THE UPPER DECK BORE FOR A REPAIR BUSHING

### FEED VALVE OPERATION

To close feed valve, turn valve knob to the right so pointer is horizontal (Figure 1). To open feed valve, turn knob to the left so pointer is in vertical position. (See Figure 2)

#### HELPFUL HINT:

Note the position of the feed valve in each of the following photos.

#### NOTE:

Prior to placing the boring machine on engine block, make sure that the bottom surface of base plate is clean and burr free. The cutter should be removed from the cutter plate and all screws are securely fastened.

1. Select proper cutter plate, install plate on shaft of Porta-Matic and secure with nut and washer. (Figure 3)
2. Place PT 2075 Porta-Matic over bore to be cut. Open feed valve and lower the cutter plate into the bore. Push down firmly on the mainshaft while rotating the cutter plate in the bore to ensure proper alignment. (See Figure 4)
3. With cutter plate centered in bore, align base plate with (3) cylinder head bolt holes in block maintaining as much baseplate-to-block contact as possible. Install washers and cap screws through baseplate and into block. (Handle may be swung up for easy access to cap screws).

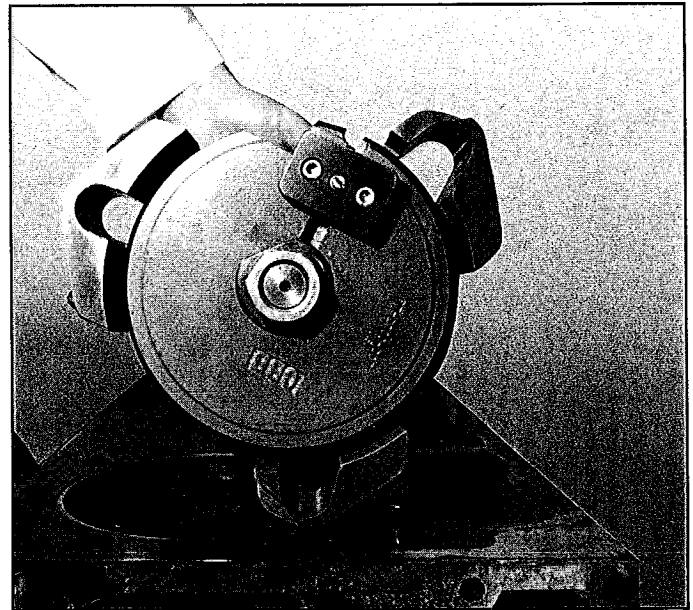

Figure 3

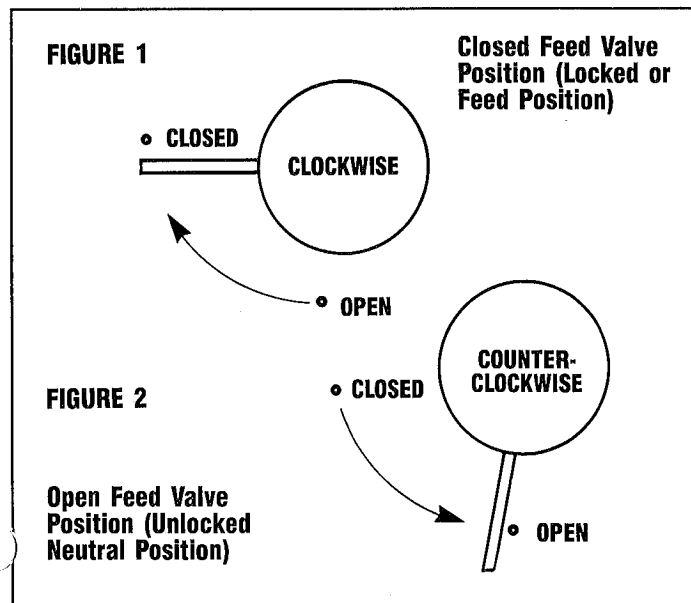

Figure 4

# KENT-MOORE

## PT-2075 PORTA-MATIC

4. Cross torque the 3 cylinder head bolts gradually to 50 ft/lbs. Swing handle down and lock in position. Rotate mainshaft of boring tool to ensure cutter plate is centered in bore. If binding occurs, loosen head bolts and repeat Steps 3 and 4. (See Figure 5)
5. Retract the cutter plate from the bore and lock it in the full up position. (See Figure 6)

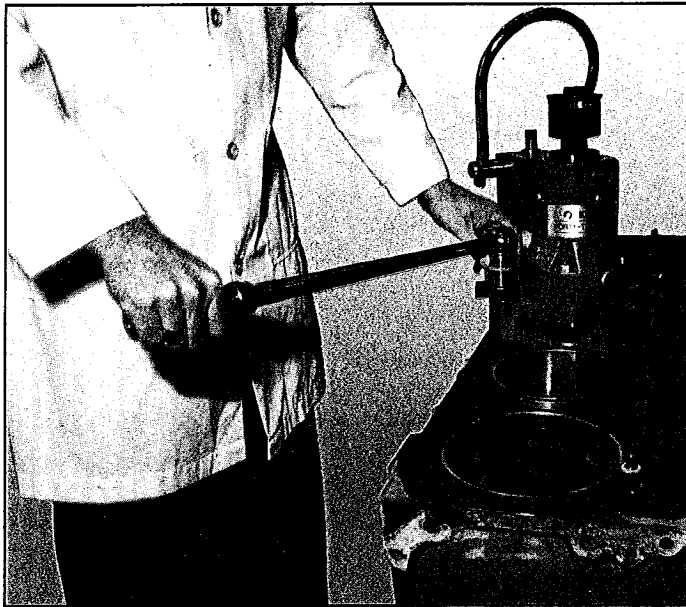

Figure 5

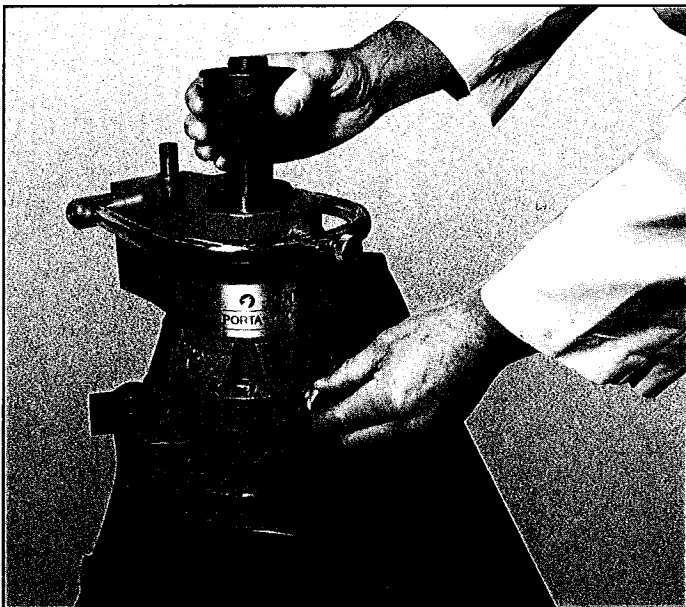

Figure 6

6. Insert the cutter all the way into the cutter plate and tighten cutter plate swivel pad set screw. Cutter should enter with noticeable drag due to ball spring detent on bottom of cutter holder plate. The cutter must fully contact the main shaft of the boring tool to assure accurate boring.

**NOTE:**

The cutter must be inserted into the cutter holder slot with the tip to the lower left side of slot. (See Figure 7)

**NOTE:**

Cutter has a shallow hole which will face downward when cutter is properly inserted into slot.

7. Place a 0.004 inch feeler gauge between the block and the cutter. Open feed valve and lower cutter plate until it rests on the feeler gauge. (See Figure 8) Tighten swivel pad set screw to secure cutter in place.

**NOTE:**

**OPTIONAL DEPTH SET SPACER INSTRUCTIONS:**

Loosen the set screw on the depth set collar and adjust it up. In most cases such as the 3406 Engine, you can attach the PT 2000-138 Depth Set Spacer Block onto the mainshaft, below the collar and resting on the Porta-Matic housing. (See Figure 9) There are some applications where PT 2000-138 cannot be used. When using the PT 2000-138 Depth Set Spacer, place the repair bushing/insert between the depth set spacer and collar. Lower depth set collar down the mainshaft so that it rests squarely on the repair bushing/insert and securely tighten the set screw. (See Figure 10)

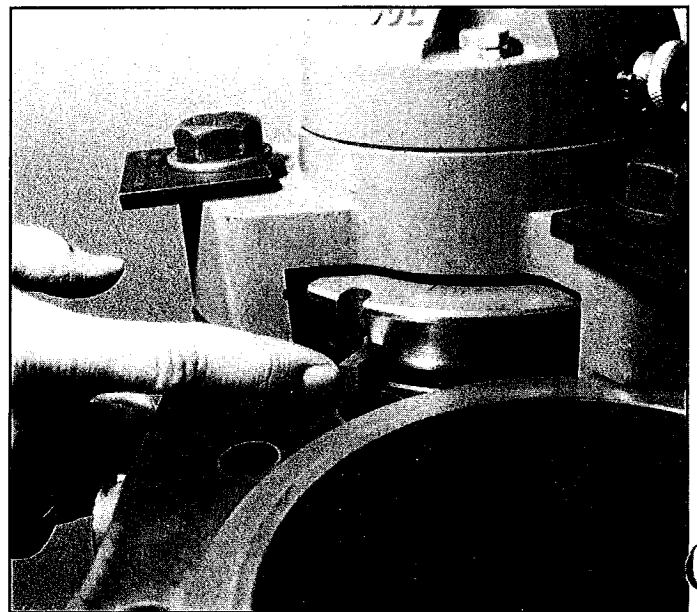

Figure 7

8. Place the bushing/insert between the depth set collar and the main housing. Then adjust the depth set collar down the mainshaft so that it rests squarely on the repair bushing/insert and securely tighten the set screw. Remove the repair bushing. This spaces the depth set collar to cut 0.004 inches less than the total height of the repair bushing being used.

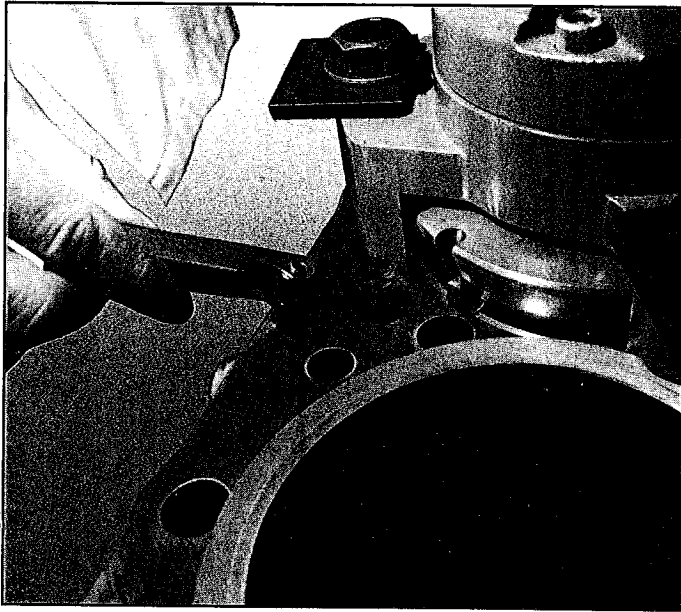

Figure 8

9. Pull mainshaft to the full upright position and lock feed valve in closed position. Remove feeler gauge. (See Figure 11)
10. Chuck the 1/2" universal drive adapter into a 5/8" or 3/4" heavy duty (8 AMP or more) electric drill (300-600 RPM) (PT 7145-A).

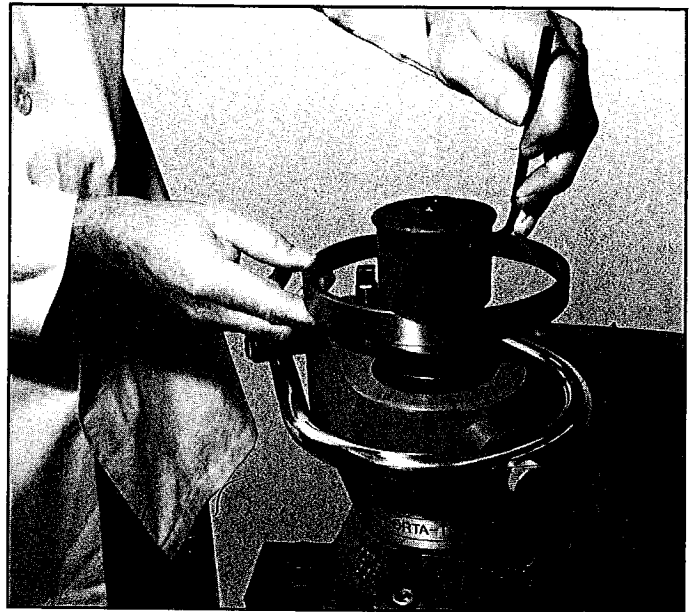

Figure 10



Figure 9

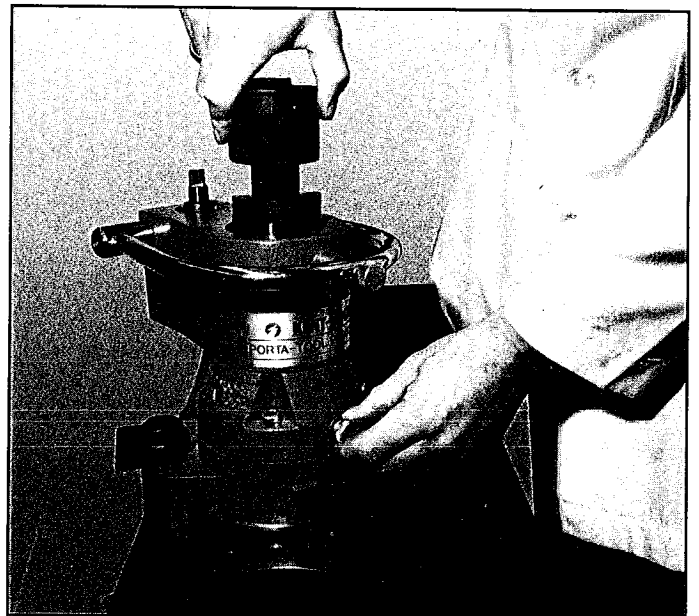

Figure 11



# KENT-MOORE

## PT-2075 PORTA-MATIC

11. Install universal drive adapter and drill onto driveshaft of Porta-Matic and prepare to bore without stopping until the machine freewheels. (See Figure 12)

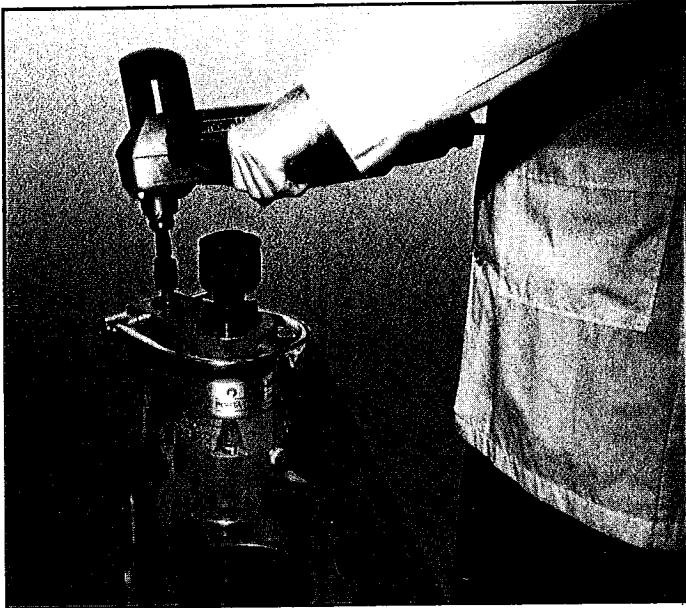

Figure 12

12. Remove the electric drill from boring machine. Open feed valve and retract cutter plate to its full up position. Close feed valve to lock in up position. (See Figure 13)

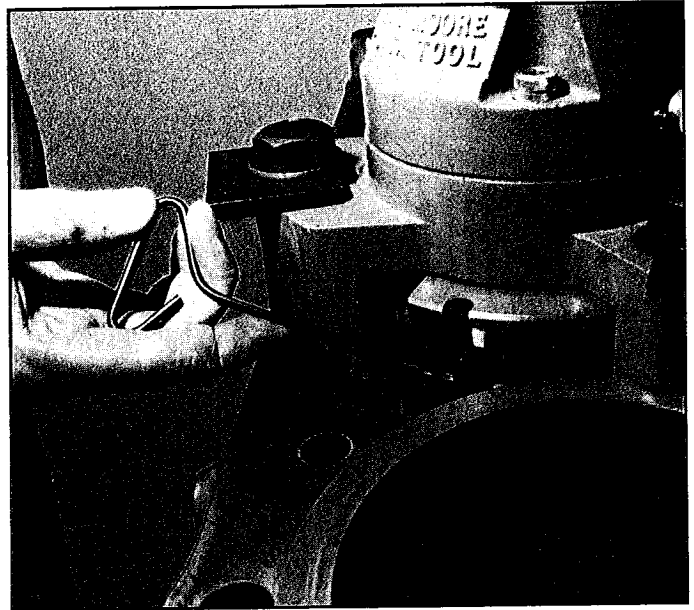

Figure 14

### NOTE:

Approximately half way through the cut, the operator should be prepared for the increased load put on the machine caused by the additional material being cut. A firm grip and a balanced stance are recommended. Operation is complete when boring machine freewheels.

13. Loosen swivel pad set screw and insert cutter removal key into shallow hole in bottom of cutter and pull, to remove cutter from plate. Remove boring machine. (See Figure 14)



Figure 13



Figure 15



14. Clean away all shavings and deburr bore with Scotch Brite Pad PT 2901. (See Figure 15)
15. Remove all chips and foreign material from the cutter recess and the access area where the cutter contacts the mainshaft. It is very simple to clean these areas with a cotton swab. Foreign material in these areas could cause the next bore to be cut oversize.

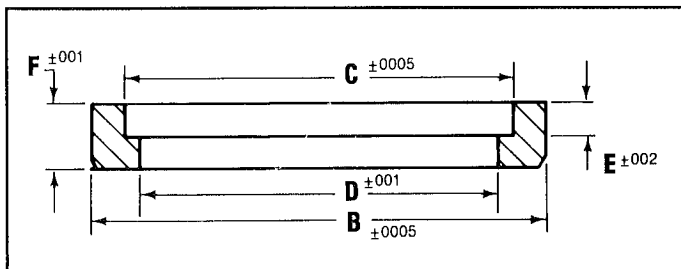

Figure 16

**NOTE:**

Diameters of the finished cut bores must be  $\pm .001$ " of the specified bore size. A cutter that has been resharpened on the flat of the carbide loses its center line and will have a different setting from that of a new cutter. A resharpened cutter should be test bored before using to determine its accuracy. If a bore is cut oversize, a special oversize bushing can be ordered. Kent-Moore stocks an oversized bushing for the 3406 engine for immediate delivery. You may also order a custom made oversize bushing manufactured to fit any existing bore so that no additional cutting will be required. See Figure 16 for ordering information required to make a special bushing.

**NOTE:**

Install the counterbore repair bushing and finish file it flush with deck before going on to the next bore. Never attempt to cut all the bores and then install repair sleeves.

16. If the block is to be resurfaced, all repair bushings should be installed first. Allow at least 4 hours after the last bushing repair before resurfacing the block. This time period is required to allow the Loctite to cure.

## INSTALLING A REPAIR BUSHING

1. Clean bore and bushing outside diameter thoroughly with PT 7270 Primer T. (See Figure 17)
2. Lightly coat the inside diameter and bottom of newly cut bore with PT 7260 Loctite Compound. (See Figure 18) Insert bushing on driver. (See Figure 19) Using hammer and the bushing driver assembly install bushing into bore until it bottoms. A solid sound can be heard when bushing bottoms. (See Figure 20)
3. When fully installed, the bushing will protrude slightly above the top of the block approximately 0.004". This protrusion must be filed even with the top of the deck (PT 2000-400 File). Remove all burrs using a scotch pad. Sand paper should never be used. (See Figure 21)



Figure 17



Figure 18

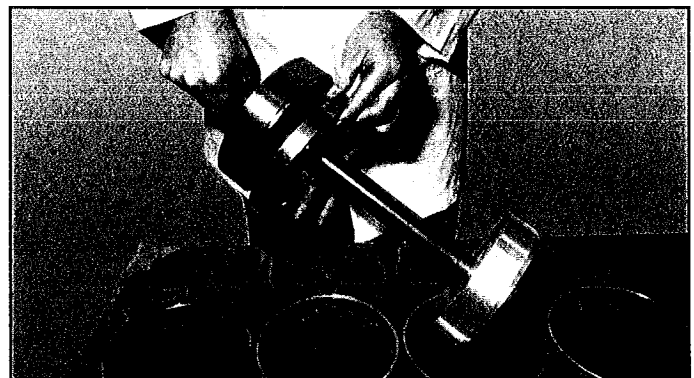

Figure 19

# KENT-MOORE

## PT-2075 PORTA-MATIC

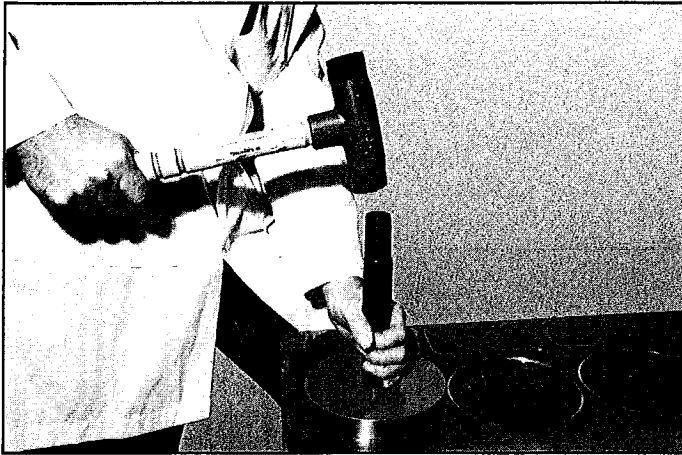

Figure 20

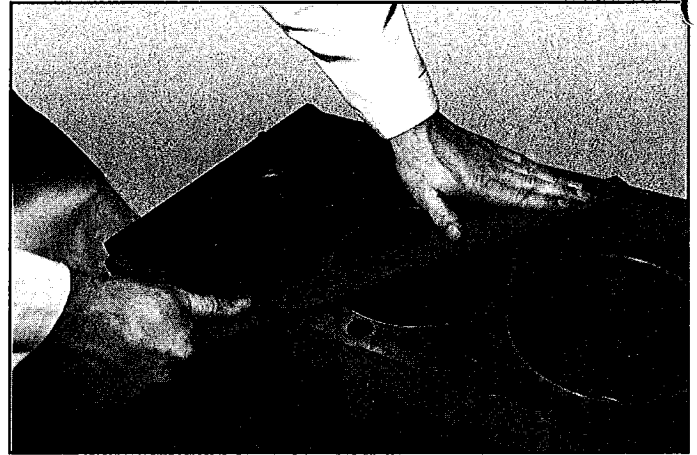

Figure 21

### PORTA-MATIC ACCESSORIES

PT 2000-400  
Finishing File



PT 2000-101  
Chip Catcher

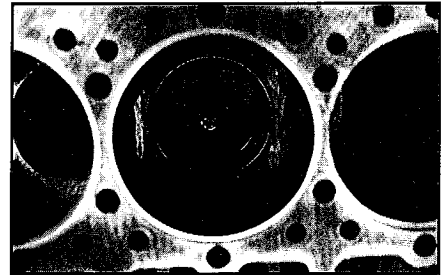

PT 2900  
Super Chip Vacuum

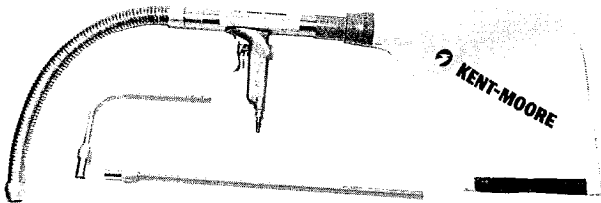

PT 7145-A  
Right Angle Drill

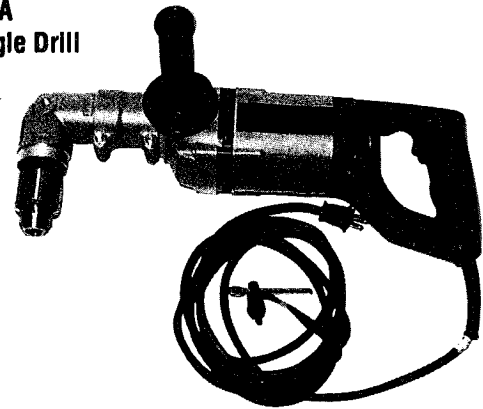

Vacuums metal chips instead of blowing them around. Compact and easier to handle than a shop vac. OSHA approved. Operates on shop air 80-150 PSI. Large reusable bag. Weighs only one pound.

PT 7260  
Loctite  
Retaining Compound



PT 7270  
Loctite Primer T



**PT 2075 PORTA-MATIC SERVICE PARTS LIST**

**A. PT 2475-1 BASE PLATE (not shown)**

- 1. RS 9104-300 Socket Head Cap Screw (3/8 - 16 X 1-3/4) (not shown)

**B. PT 2000-137 DRIVE UNIT**

- 2. RS 3601-175 Jam Nut (7/8 - 14 Thread)
- 3. PT 2000-17 Cut Off Washer
- 4. PT 2000-42 1/4" Square Key
- 5. PT 2000-148 Lower Seal
- 6. RS 22200-32 Retaining Ring
- 7. RS 3000-30 "O" Ring
- 8. PT 2000-54 Drive Bracket Assembly
- 9. RS 31004-900 Hex. Socket Pipe Plug (1/8-27 NPT)
- 10. RS 9106-660 Button Head Cap Screw (1/2-20 X 1/2)
- 11. PT 2000-143 Chain Guard Assembly
- 12. PT 2000-5 Spline Washer
- 13. PT 2100-10 Spline Sprocket
- 14. PT 2000-203 Depth Collar
- 15. PT 2000-204 Handle
- 16. PT 2000-149 Handle Screw (3/8 Thread)
- 17. PT 2000-056 Drive Chain Assembly

QTY.

4

1

1

1

1

1

2

1

1

3

1

1

1

1

1

1

1

**C. PT 2000-54 DRIVE BRACKET ASSEMBLY**

- 18. PT 2000-57 Spacer
- 19. PT 2000-105 Drive Sprocket
- 20. PT 2000-3 Drive Shaft

1

1

1

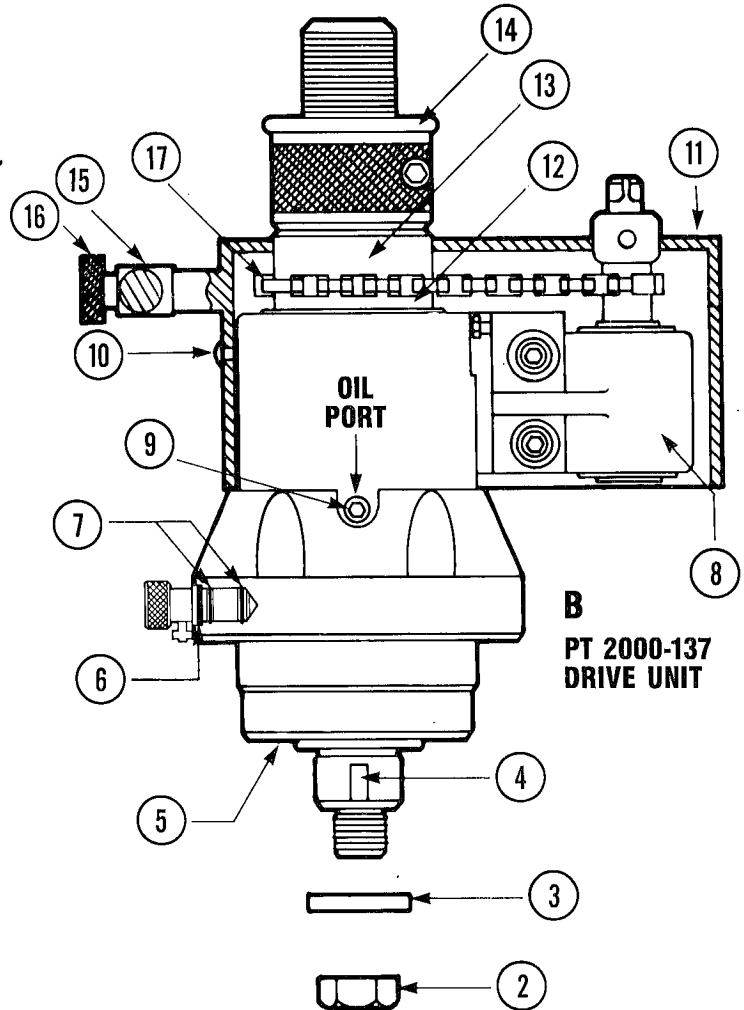

**B**  
PT 2000-137  
DRIVE UNIT

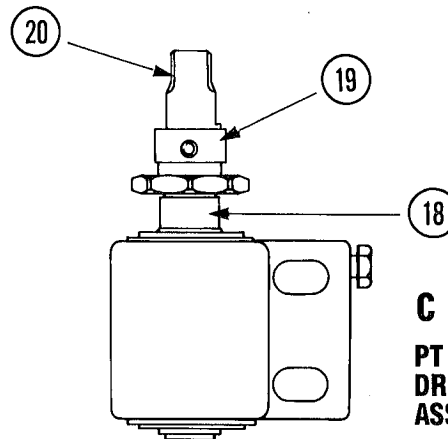

**C**  
PT 2000-54  
DRIVE BRACKET  
ASSEMBLY

---

**SP<sup>x</sup>**

*Exponent of Excellence*

---

**KENT-MOORE**

*Heavy Duty Group  
Kent-Moore Division  
SPX Corporation*

*29784 Little Mack  
Roseville, MI 48066-2298*

*1-800-328-6657 (USA, Canada)  
Telex 244040 KMTR UR  
Fax 313-578-7375*